

EHPD-ECO

Electric High Pressure Diffuser-Economic



Operation process of Electric High Pressure Diffuser-Economic (EHPD-ECO):

When the back-end sampling device begins to sample, the compressed gas to be tested is decompressed to atmospheric pressure dynamically, in real time, and is delivered to the device. When the sampling device stops, the EHPD-ECO closes the gas output automatically.

The EHPD-ECO can be coupled with particle counter, air sampler and any other active sampling devices for detecting and analyzing the atmosphere, nitrogen, carbon dioxide, argon, oxygen and other inert gases under high pressure, only use in non-flammable and non-explosive area.

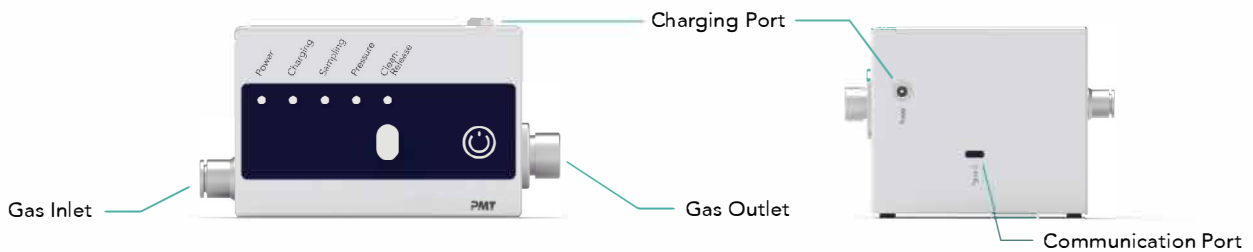

High compatibility

Compatible with most brands of airborne particle counters and bioaerosol samplers with different flow rates and any other types of active gas sampling devices.

Accurate and reliable

The built-in differential pressure manometer and electromagnetic valve can provide accurate gas volume for the back-end detecting device.

No overflow

The output volume is equal to the required sampling volume.

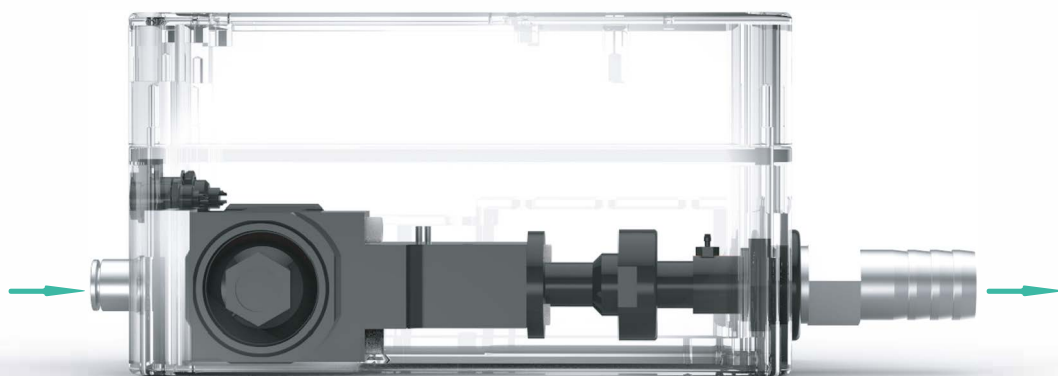

Note: Path of cleaning mode

Application

Compressed gas is decompressed to atmospheric pressure by the Electric High Pressure Diffuser - Economic and transported to the back-end sampling/detection device for sampling or detection.



Application1: Compressed gas particle detection

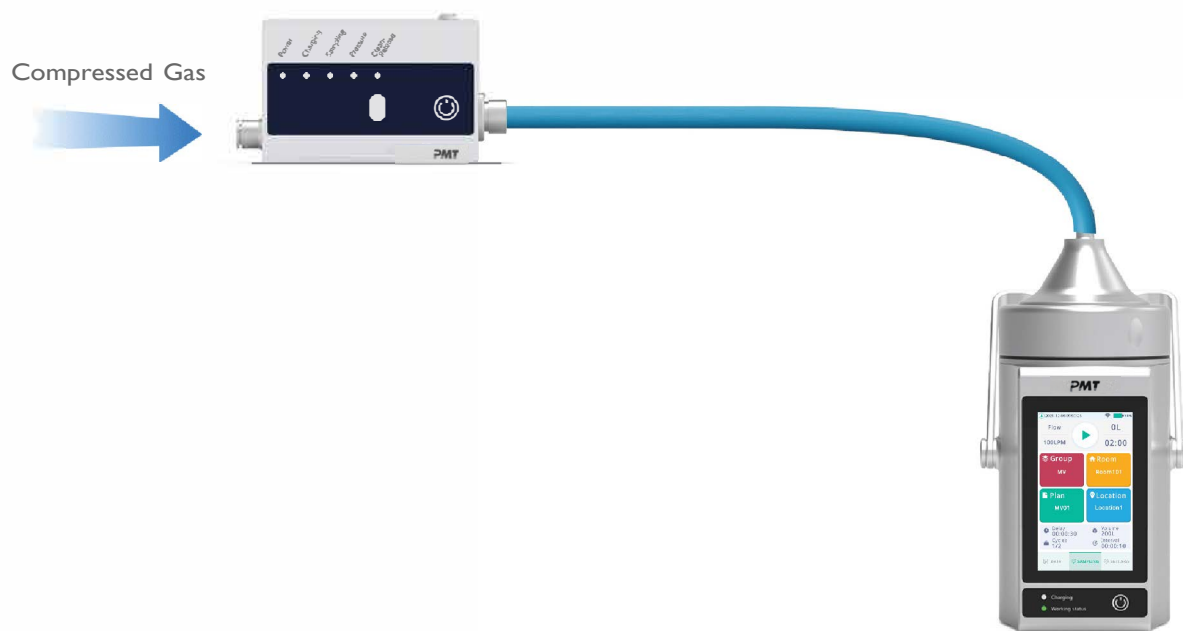

Application2: Compressed gas microbial detection

Specification Sheet

Specification	Electric High Pressure Diffuser-Economic I EHPD-ECO
Gas type	Air, N ₂ , CO ₂ , Ar, O ₂ and other inert gases (only for non-flammable and non-explosive areas)
Flow rate	≥2LPM
Inlet relative pressure	1-7bar
Inlet tube diameter	ID: 5mm, OD: 8mm
Outlet tube diameter	ID: 6mm, 8mm, 12mm, 14mm, 16mm, 20mm selectable
Dimensions	105(H) × 70(W) × 90(D) mm (with foot mat)
Weight	0.91 kg (1.98lbs)
External surface	Anodized aluminum
Power	24V±10% AC adapter
Battery	3 x 3.7 V, 3100mAh rechargeable lithium battery, battery life over 6 hours
Communication	TYPE C
Data storage	N/A
Display	N/A
Language	N/A
Max power consumption	3.3W
Operating conditions	Temperature: 5°C-30°C, relative humidity up to 80%
Storage conditions	Temperature: 0°C-40°C, relative humidity up to 80%
Safety	N/A
Warranty	2 years after activation

Ordering Information

Name	Model	Ordering Number
Electric High Pressure Diffuser-Economic I EHPD-	E310	MACHE310

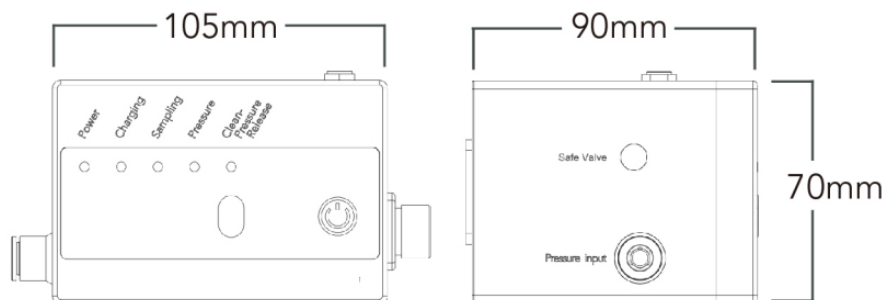

PMT reserves the right to change specifications without notice.
 Contact : info@pmt.eu or your local distributor for more details.

Certified with: **CE**

