

EX DELTA II Series

Renewal



Battery powered EX DELTA II



Smart type EX DELTA II

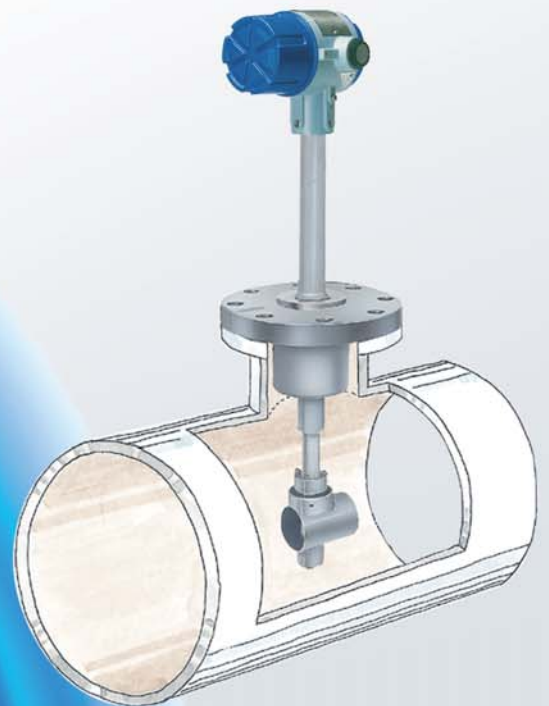

Insertion type EX DELTA II

An extensive product lineup that enables flexible measurement system configuration.

EX DELTA II Series

High performance supports various applications

With a combination of a triangular-section bluff body and a piezoelectric sensor, the flow rate of liquid, gas, and steam can be measured to a high degree of accuracy.

User-friendly and low-cost

Simple and durable design provides ease of use and maintainability, substantially saving initial cost, running expense, and total cost.

Increased safety

A hard-to-clog structure with minimum seals. The replaceable sensor in particular enables servicing and maintenance while the sensor is installed without interrupting the flow.

Saves energy and space

Low pressure loss is synonymous with energy saving. A dedicated flow straightener also reduces installation space.

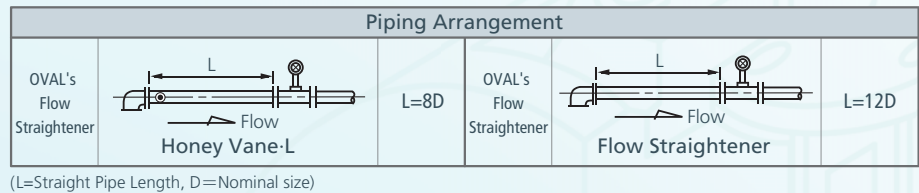

Operating temperature range: -30 to +460°C (high temperature type)

The minimum temperature of -196°C is available by special request. Explosionproof protection is available for -196°C to +420°C.

Vortex detection principle

The vortex flowmeter is configured with a bluff body that generates Karman vortices, a sensor that detects vortices, and a converter that processes signals detected by the sensor. When the flow creates Karman vortices alternately on each side of the bluff body, alternating stress on the sensor is generated. This is detected by the piezoelectric element, amplified and shaped by the converter, and then obtained as a pulse proportional to the flow velocity.

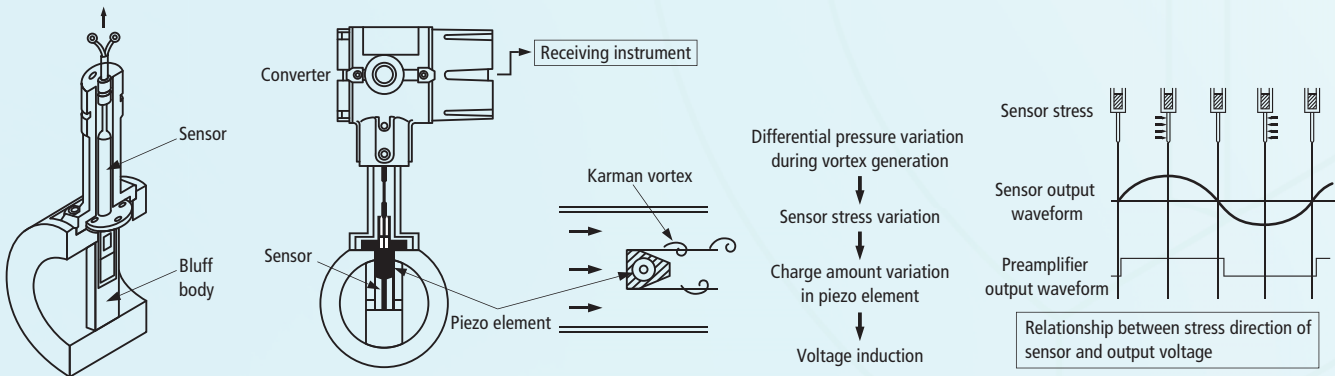

Battery powered EX DELTA II

- No power supply installation required
- Available with separate type converter and explosionproof protection
- 7 year battery life when operated 24 hours a day (Integral converter type)
- Large and clear digital display including total and resettable counters, instant flow rate and alarm displays
- Can be installed horizontally or vertically, making it optimal for use in place of area flowmeters which are limited in their installation position.

- Digital display



Maintenance/inspection can be carried out without stopping the line

Replaceable sensor

[Nominal diameter] 15 to 300mm

- Maintenance and inspection of vortex detector can be done without disconnecting the flowmeter from piping or stopping the fluid flow.
- Bypass piping is unnecessary
- Suitable for long-term continuous operation process

Gets rid of bypass piping:

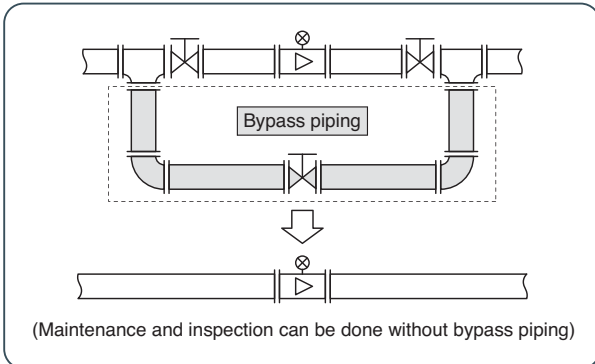

The insertion type reduces construction cost and maintenance cost

Insertion type EX DELTA II

[Nominal diameter] Fixed type: 200 to 2,000mm
Hot-tap type: 400 to 2,000mm

- Considerably reduces construction and maintenance costs related to fluid measurement of large-diameter piping.
- Flow rate can be measured by just inserting the probe in a newly installed or existing piping.
- The hot-tap type enables maintenance and inspection of vortex detection sensor without stopping the flow of fluid.
- The hot-tap type is most suitable if the bypass piping is unavailable.

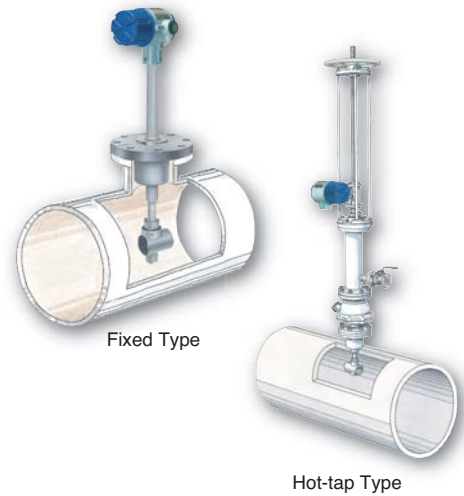

EX DELTA II · DIA

- The diamond-shaped bluff body with superior characteristics is adopted.
- Separate-sensor configuration separates the sensor from the bluff body.
- Suitable for the measurement of fluids with easily-accumulating components.

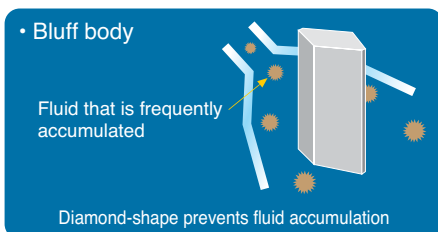

Separate type converter

- Suitable for where the piping is densely installed, high places, dangerous zones, etc.
- The converter can be installed up to 200m (Max. 50 m for the battery type) away from the flowmeter body.
- Multiple converters of dispersedly located flowmeters can be installed in one location.



■ General Specifications

Item		Standard Type	Insertion Type	DIA
Nominal size	Wafer type (fixed sensor)	10 to 150mm	—	15 to 80mm
	Flanged type (fixed sensor or replaceable sensor)	15 to 300mm	—	15 to 80mm
	Applicable pipeline diameter	—	200 to 2000mm (mounted on a 100mm flange)	—
Applicable fluid	Liquid	○	○	○
	Gas	○ (Battery powered type: min. 15mm)	○	×
	Steam	○ (Nominal size: min. 15mm)	○	×
Accuracy		(1) Standard · Nominal size: 10mm ±2% of full scale or better · Nominal size: 15 to 300mm ① ±1% of reading or better ② ±1% of full scale or better (2) Max. flow velocity: 80m/s available. · Nominal size: only 80mm and bigger for gas and steam measurement. ① ±1.5% of reading or better ② ±1.5% of full scale or better (3) Liquid only: High accuracy (option) · Nominal size: 15mm to 300mm ① ±0.75% of reading or better ② ±0.75% of full scale or better	±2% of full scale or better	±1% of reading or better or ±1% of full scale or better
Flow range ※2	Liquid (Water)	0.2 to 2510 m ³ /h	72 to 67800 m ³ /h	0.82 to 172 m ³ /h
	Gas (0.2MPa Air)	2 to 15000 m ³ /h	923 to 565000 m ³ /h	—
	Steam (0.5MPa Saturated steam)	0.02 to 47.6 t/h	3.06 to 1790 t/h	—
Operating temperature range		Ambient temperature type: -30 to +120°C (Fixed sensor only) Standard type: -30 to +300°C High temperature type: -30 to +460°C (Replaceable sensor only) Cryogenic type: -196 to +300°C	-10 to +300°C	Ambient temperature type: -30 to +120°C (Fixed sensor only) Standard type: -30 to +300°C High temperature type: -30 to +460°C (Replaceable sensor only)
Max. operating pressure (Depends on process connection type)		5.00MPa	1.37MPa	5.00MPa
Converter (integral or separate type)	Smart	Display	No display or Total/instantaneous flowrate	
		Output	Current pulse (Factored, Unfactored), Open collector pulse (Factored, Unfactored), Analog output	
		Other	Calculation (Mass flow fixed calculation, normal flow fixed calculation)	
	Battery powered	Display	Instant, total, alarm, operation lock, instant flow rate bar graph	
		Output	None	
		Other	Calculation (Mass flow fixed calculation, normal flow fixed calculation)	
Construction	Non-explosionproof or explosionproof			
Power Supply	Smart converter	12 to 45VDC		
	Battery powered	3.6V lithium-metal battery (TL-5930/F) Battery life: 7 years (integral type) or 4 years (separate type)		

※: For detailed specifications, see the general specification sheet of each model.

Related products tailored to applications

• DELTAFLOW Type F

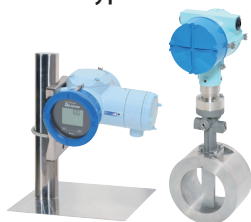

The DELTAFLOW Type F measures the flow rate by detecting the vortices generated by flow velocity change in the following manner; temperature change in thermistor sensor → resistance change → pulses proportional to the flow velocity.

As the actual flow rate is measured, the measurement is not affected by changes in temperature, pressure, and physical properties of the fluid.

• Hybrid Multi DELTA



Made possible with hybrid technology which combines two sensors of different principles, vortex and thermal, the Hybrid Multi DELTA is capable of measuring extra-wide flow ranges as wide as 1:900 with just one unit. This flowmeter is optimal for managing the usage of compressed air.

• DELTA FLOWPET-DX



The DELTA FLOWPET-DX with pressure compensation is a piezoelectric vortex flowmeter with a built-in pressure sensor, capable of measuring the pressure-compensated mass flow rate of saturated steam and gas.

The DELTA FLOWPET-DX without pressure compensation can measure the volumetric flow of liquid, gas, and steam.

※1: The configuration may vary depending on the model.

※2: Flow range shown above is the sum of all sizes.