

9301P and 9501P PoE Remote Particle Counters

0.1 CFM (2.83 LPM)



The 9301P and 9501P PoE particle counters provide a range of particle size measurement from 0.3 to 25.0 μm at a flow rate of 0.1 CFM (2.83 LPM). These sensors allow for efficient particle counting with specifications that exceed the ISO 21501-4 and JIS B9921 calibration standards.

These sensors have 6 user-selectable particle size channels (up to 30 channels optional) and are equipped with an internal pump and manifold and do not require an external vacuum source. Integration into a building automation or facility monitoring system is easy via MODBUS™ TCP/IP over Ethernet or WiFi (802.11 b/g).

9301P and 9501P: Features and Benefits

- 9301P: Measures 0.3 μm to 25 μm
- 9501P: Measures 0.5 μm to 25 μm
- 0.1 CFM (2.83 LPM) flow rate
- Long life laser diode technology
- Measures up to 30 channels of simultaneous data
- Accurate in high particle concentration environments
- Internal vacuum pump
- Internal HEPA filter
- User-selectable channel sizes
- Stores up to 65,000 sample records for on-board data redundancy
- (Optional) temperature and relative humidity probe available
- Connect via MODBUS™ TCP/IP over Ethernet or WiFi (802.11 b/g)
- Complies with ISO 21501-4 and JIS B9921 standards
- Alarm light
- LED Indicators
- Seamless integration into a facility monitoring system
- Lightweight stainless steel enclosure
- 5 year warranty



Specifications

| Model | 9301P, 9301P-TCP, 9301P-PoE, and 9301-WiFi | 9501P, 9501P-TCP, 9501P-PoE, and 9501-WiFi |
|------------------------|---|--|
| Size Range | 0.3 µm to 25 µm | 0.5 µm to 25 µm |
| Size Channels | Factory calibrated at 0.3, 0.5, 1.0, 2.5, 5.0, 10.0 µm | Factory calibrated at 0.5, 0.7, 1.0, 2.5, 5.0, 10.0 µm |
| Number of Channels | 6 channels (up to 30 optional) | 6 channels (up to 30 optional) |
| Counting Efficiency | 50% @ 0.3µm; 100% for particles > 0.45 µm per JIS | 50% @ 0.5µm; 100% for particles > 0.75 µm per JIS |
| Flow Rate | 0.1 CFM (2.83 LPM) | |
| Concentration Limits | 10,000,000 particles/ft ³ @ 10% coincidence (per ISO 21501-4), 20,000,000 particles/ft ³ @ 10% coincidence (as tested and validated) | |
| Light Source | Long life laser diode | |
| Zero Count | <1 count / 60 minutes (<1 particles / 6 ft ³). No fault count subtraction. | |
| Alarms | Channel alarms on Raw counts, concentrations or mass (alarms on environmental sensors optional) | |
| Calibration | NIST traceable | |
| Vacuum Source | Internal vacuum pump with HEPA filter | |
| Filtered Exhaust | Internal HEPA filter | |
| Airflow | Internally monitored | |
| Configuration/Download | USB mini-B | |
| Alarm | Alarm LED ring | |
| Communication Modes | MODBUS™ TCP/IP over Ethernet or WiFi (802.11 b/g) | |
| Environmental Sensor | (Optional) Temp and RH probe 32° to 122°F (0° to 50°C) ±1°F (0.5°C), 15-90% ±2% relative humidity | |
| Standards | ISO 21501-4 and JIS B9921 | |
| Instrument Calibration | Recommended minimum once per year | |
| External Surface | Stainless steel | |
| Dimensions (L x W x H) | 3.59" x 1.80" x 4.86" (9.1 cm x 4.5 cm x 12.3 cm) | |
| Weight | 1.71 lb. (780 grams) | |
| Accessories | Operating manual and Instrument Management Software (IMS) on USB flash drive, Calibration certificate | |
| Temperature | RH Probe 32-140°F (0-60°C) ±1°F (0.5°C), 0-100% ±2% | |
| Optional Accessories | Printed manual, barb fittings, mounting bracket and sample tubing, Power Supply | |
| Buffer Memory | 65,000 sample records (rotating buffer) including particle count data and environmental data | |
| Sample Time | 1 second to 99 hours | |
| Power | 9 - 24 VDC (< 2.5 watts) or PoE (compliant with IEEE802.3af) | |
| Operating Conditions | 41° to 104°F (5° to 40°C) / 20% to 95% non-condensing | |
| Storage Conditions | 32° to 122°F (0° to 50°C) / Up to 98% non-condensing | |
| Warranty | 5 year warranty | |

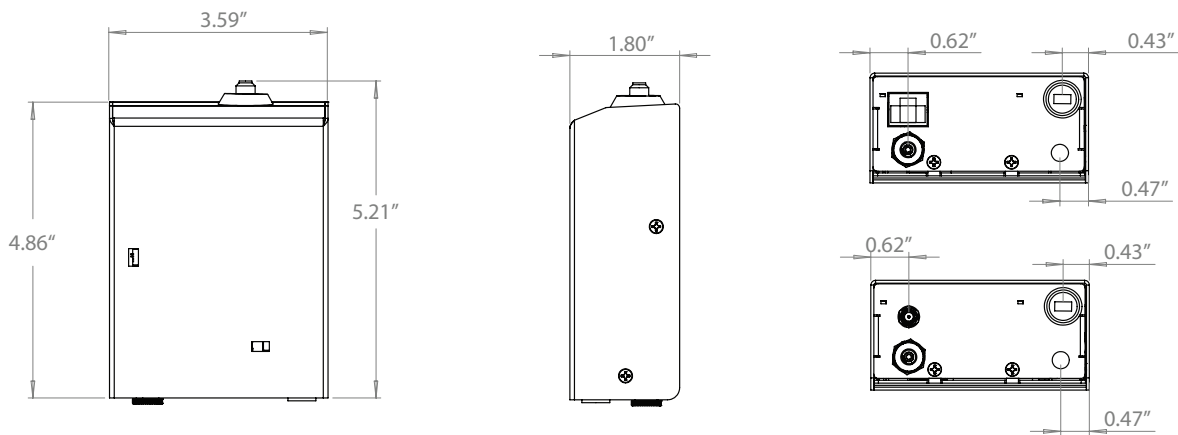

REV 20240620-9301P/9501P-XXXX



INDUSTRIE AUTOMATION GRAZ Ing. W. Häusler GmbH AUTALER STRASSE 55 A-8074 RAABA-GRAMBACH
 TEL: +43 316 405 105 FAX: +43 316 405 105 22 E-MAIL: OFFICE@IAG.CO.AT WWW.IAG.CO.AT

