

**Extendable vane wheel flow sensors,
 optional with \pm directional sensing and integrated PT100 sensor and accessories
 for connection to a fixed or portable evaluation unit**

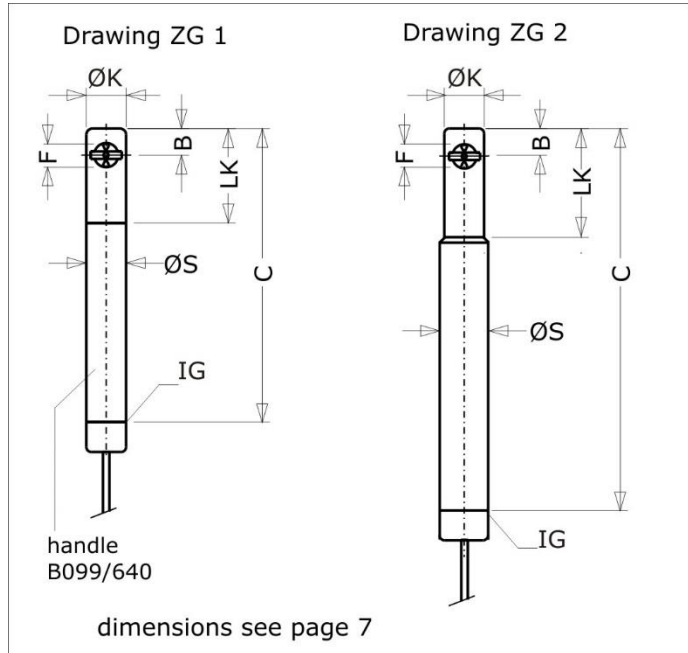

Measurable variables

- flow velocity v [m/s] and
- flow rate [m³/h] in air/gases and water/liquids
- conversion to standard velocity/standard flow rate by measuring or entering working pressure and temperature parameters

Measuring range

- 0.2 ... 120 m/s gases
- 0.01 ... 10 m/s liquids

Medium

- air, gas mixtures and clean gases
- water/liquids

Funktionsprinzip

- vane wheel flow sensor
- sensing the vane rotation; non-contact by means of inductive proximity switch

Design

- insertion probe with fixed cable, extendable

Examples of application

- flow measurement e.g. of air, exhaust gas, process gas
- in processes with varying and/or unknown gas compositions
- flow monitoring in pharmaceutical installations
- monitoring neutralisation processes
- use up to 550 °C
- measurement of flammable liquids
- measuring in surface waters
- measuring in non-conducting liquids, for example such as ultra pure water in the semiconductor industry
- recommended according to DIN EN ISO 16911, normative for verification of automatic measuring equipment

Connection possibilities

- portable and fixed evaluation units with sensor input

Advantages

- accurate measured values even in varying and/or unknown gas compositions
- turndown ration approx. 1:100
- no distortion of values due to thermal radiation
- optional application in category 2 (zone 1)
- universal application spectrum
- extendable
- optional with \pm directional sensing
- optional with integrated PT100 sensor
- small pressure loss

Humidity in teh sample gas

- relative gas humidity of less than 100 % has no impact on the measurement uncertainty

Particles in the medium

- can cause restriction in the fatigue strength of the vane wheel set

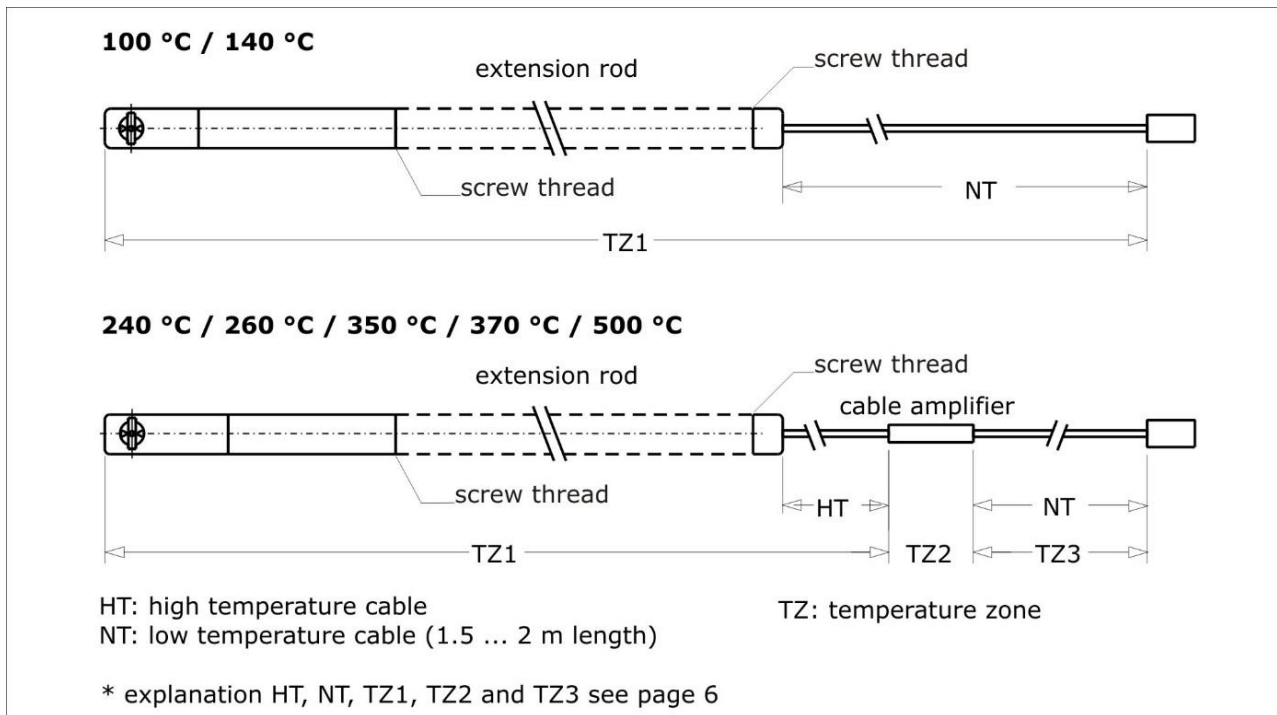

Basic types

measurement in air and other gaseous media

type	article no.	alt. MR*	article no.	alt. MR*	article no.	alt. MR*	article no.
extendable sensors Ø 25 mm (s. page 1, drawing ZG1)							
ZS25GA-mn20/140/p6	B002/000	mn40	B002/001	mn80	B002/002	mn120	B002/003
ZS25GE-mn20/100/p10	B002/100	mn40	B002/101	mn80	B002/102	mn120	B002/103
ZS25GE-mn20/260-2/p10	B002/112	mn40	B002/113	mn80	B002/114	mn120	B002/115
ZS25GT-mn20/100/p10	B002/400	mn40	B002/401	mn80	B002/402	mn120	B002/403
ZS25GT-mn20/260-2/p10	B002/412	mn40	B002/413	mn80	B002/414	mn120	B002/415
extendable high temperature sensors Ø 25 mm (s. page 1, drawing ZG2)							
ZS25/27GE-mn20/370-2/p6	B002/140	mn40	B002/141	mn80	B002/142	mn120	B002/143
ZS25/27GE-mn20/500-2/p6	B002/152	mn40	B002/153	mn80	B002/154	mn120	B002/155
extendable sensors Ø 25 mm with ± directional sensing (s. page 1, drawing ZG1)							
ZSR25GA-mn20/140/p6	B002/500	mn40	B002/501	mn80	B002/502	mn120	B002/503
ZSR25GE-mn20/100/p6	B002/504	mn40	B002/505	mn80	B002/506	mn120	B002/507
ZSR25GE-mn20/240-2/p6	B002/512	mn40	B002/513	mn80	B002/514	mn120	B002/515
ZSR25GT-mn20/100/p6	B002/508	mn40	B002/509	mn80	B002/510	mn120	B002/511
ZSR25GT-mn20/240-2/p6	B002/516	mn40	B002/517	mn80	B002/518	mn120	B002/519

*alt. MR = alternative measuring ranges

Basic types (cont.)

measurement in air and other gaseous media

type	article no.	alt. MR*	article no.	alt. MR*	article no.	alt. MR*	article no.
extendable sensors Ø 25 mm with integrated PT100 sensor (s. page 1, drawing ZG1)							
FT25GA-mn20/140/p3	B002/600	mn40	B002/601	mn80	B002/602	mn120	B002/603
FT25GE-mn20/100/p6	B002/604	mn40	B002/605	mn80	B002/606	mn120	B002/607
FT25GE-mn20/260-2/p6	B002/608	mn40	B002/609	mn80	B002/610	mn120	B002/611
FT25GT-mn20/100/p6	B002/612	mn40	B002/613	mn80	B002/614	mn120	B002/615
FT25GT-mn20/260-2/p6	B002/616	mn40	B002/617	mn80	B002/618	mn120	B002/619

extendable sensors Ø 30 mm (s. page 1, drawing ZG1)

ZS30GA-md20/140/p6	B014/000						
ZS30GE-md20T/100/p10	B014/100						
ZS30GE-md20T/260-2/p10	B014/101						
ZS30GE-md20T/350-2/p10	B014/102						
ZS30GT-md20/100/p10	B014/300						

extendable sensors Ø 30 mm with ± directional sensing (s. page 1, drawing ZG1)

ZSR30GA-md20/140/p6	B014/500						
ZSR30GE-md20T/100/p6	B014/501						
ZSR30GE-md20T/240-2/p6	B014/503						
ZSR30GT-md20/100/p6	B014/502						
ZSR30GT-md20/240-2/p6	B014/504						

extendable sensors Ø 30 mm with integrated PT100 sensor (s. page 1, drawing ZG1)

FT30GA-md20/140/p3	B014/600						
FT30GE-md20T/260-2/p6	B014/602						

measurement in water and other liquids

extendable sensors Ø 25 mm (s. page 1, drawing ZG1)

ZS25GFA-mn20/140/p6	B002/060	mn40	B002/061				
ZS25GFE-mn20/100/p10	B002/160	mn40	B002/161				
ZS25GFE-mn20/260-2/p10	B002/162	mn40	B002/163				
ZS25GFT-mn20/100/p10	B002/460	mn40	B002/461				

extendable sensors Ø 25 mm with ± directional sensing (s. page 1, drawing ZG1)

ZSR25GFA-mn20/140/p6	on request	mn40	B002/560				
ZSR25GFE-mn20/100/p6	B002/561	mn40	B002/562				
ZSR25GFE-mn20/240-2/p6	B002/565	mn40	on request				

extendable sensors Ø 25 mm with integrated PT100 sensor (s. page 1, drawing ZG1)

FT25GFA-mn20/140/p6	B002/660	mn40	B002/661				
FT25GFE-mn20/100/p6	B002/662	mn40	B002/663				
FT25GFE-mn20/260-2/p6	B002/664	mn40	B002/665				
FT25GFT-mn20/100/p6	B002/666	mn40	B002/667				
FT25GFT-mn20/260-2/p6	B002/668	mn40	B002/669				

***alt. MR = alternative measuring ranges**

Basic types (cont.)

measurement in water and other liquids

type	article no.
------	-------------

extendable sensors Ø 30 mm (s. page 1, drawing ZG1)

ZS30GFA-md20/140/p6	B014/060
ZS30GFE-md20T/100/p10	B014/160
ZS30GFE-md20T/260-2/p10	B014/161
ZS30GFE-md20T/350-2/p10	B014/162
ZS30GFT-md20T/100/p10	B014/360

Model designation (examples)

ZS	25		GF	E	-mn40		100		p10
ZSR	30		G	A	-md20		140		p6
ZS	25	/27	G	E	-mn20		370	-2	p6
FT	30		G	E	-md20	T	260	-2	p6
(1)	(2)	(3)	(4) ...	(5)	(6)	(7)	(8)	(9)	(10)

(1) Sensor type

Description	Design
ZS	cylindrical probe
ZSR	cylindrical probe with ± directional sensing
FT	cylindrical probe with integrated PT100 sensor

(2) Sensor diameter

diameter of sensor head ØK (see page 1)	
25	head diameter 25 mm
30	head diameter 30 mm

(3) Shaft diameter

diameter of sensor shaft ØS (s. page 1, drawing ZG2)	
/27	shaft diameter 27 mm

(4) Medium

... G ...	air/gases
... GF ...	air/gases and water/liquids

Ingress protection cable outlet

sensor design ... GF ...	IP68
sensor design ... G ...	IP50

(5) Materials in contact with the medium *

Design	Material sensor	Material Sealing	others
... A ... aluminium	AlCuMgPb or AlCuBiPb	FKM, silicone	PSU, PVDF
... E ... stainless steel	stainless steel 1.4404/AISI 316L, 1.4305, 1.4571	FKM, PTFE, graphite	PVDF, vespel, ceramics Al ₂ O ₃
... T ... titanium	titanium 3.7035 (grade 2)	FKM, PTFE	PVDF, vespel, ceramics Al ₂ O ₃

* Not all mentioned materials are used in every sensor. Materials may differ for individual sensors. Detailed information about a desired sensor on request!

(6) (7) Measuring ranges (with an air/gas density of approx. 1.2 kg/m³) / vane wheel type if the vane wheel material differs to the sensor material, a material code is added to the vane wheel type (e.g. „T“ at md3T)

sensors with Ø 25 mm

material sensor	material vane wheel	vane wheel type	measuring range air/gases	measuring range water/liquids (no cavitation)
aluminium	aluminium	mn20	0.3 ... 20 m/s	0.03 ... 7.5 m/s
		mn40	0.4 ... 40 m/s	0.04 ... 10 m/s
		mn80	0.8 ... 80 m/s	
		mn120	1.2 ... 120 m/s	
stainless steel	stainless steel	mn20	0.4 ... 20 m/s	0.04 ... 7.5 m/s
		mn40	0.5 ... 40 m/s	0.05 ... 10 m/s
		mn80	1.0 ... 80 m/s	
		mn120	1.4 ... 120 m/s	
titanium	titanium	mn20	0.3 ... 20 m/s	0.03 ... 7.5 m/s
		mn40	0.4 ... 40 m/s	0.04 ... 10 m/s
		mn80	0.8 ... 80 m/s	
		mn120	1.2 ... 120 m/s	

sensors with Ø 30 mm

material sensor	material vane wheel	vane wheel type	measuring range air/gases	measuring range water/liquids (no cavitation)
aluminium	aluminium	md20	0.2 ... 20 m/s	0.01 ... 3 m/s
stainless steel, titanium	titanium	md20T	0.3 ... 20 m/s	0.01 ... 3 m/s
		md3T	0.3 ... 3 m/s	

Measurement uncertainty / repeatability with a gas density of approx. 1.2 kg/m³

Linearisation of characteristics	all types	up to < 0.9 % of measured value + 0.25 % of terminal value ***
Frequency response characteristics (interchangeability is guaranteed)	ZS, ZSR, FT	< 1.5 % of measured value + 0.5 % of terminal value (up to 40 m/s)
Repeatability		±(0.05 % of measured value + 0.02 m/s)

The lowest measurement uncertainties in the field are attained with calibrations as close as possible to the operating conditions. For this, the measurement results obtained can be implemented as characteristic in the evaluation unit. Information and details on the measurement uncertainties according to the calibrated measurement standards can be found in the calibration documents 'U325 and U183'.

*** on request, in the calibration range of the respective accredited test bench

Measurement uncertainty / repeatability in water *

Linearisation of characteristics	all types	< 1 % of measured value + 0.5 % of terminal value **
Frequency response characteristics (interchangeability is guaranteed)	ZS, ZSR	< 1.5 % of measured value + 0.5 % of terminal value
Repeatability		±(0.05 % of measured value + 0.02 m/s)

The lowest measurement uncertainties in the field are attained with calibrations as close as possible to the operating conditions. For this, the measurement results obtained can be implemented as characteristic in the evaluation unit. Information and details on the measurement uncertainties according to the calibrated measurement standards can be found in the calibration documents 'U325 and U183'.

* for water and liquids with a viscosity of up to approx. 0.0002 m²/s (200 cSt)

** on request, in the calibration range of the respective test bench

optional

ISO or DAkkS Calibration certificate v/FA*

calibration medium air, 6 calibration values in the measuring range

article no.: KLB

* An engraved dot on the sensor head indicates the upstream side during calibration. Details of additional calibration values or customised calibrations can be found in document 'U183 Calibration' or are available on request

(8) Permissible temperature of the medium* / ambient temperature*

design	temperature of the medium	ambient temperature (see drawings, page 2)		
		TZ1	TZ2	TZ3
... 100 ...	-20 ... +100 °C (c)	-20 ... +100 °C	-	-
... 140 ...	-20 ... +140 °C (c)	-20 ... +140 °C	-	-
... 240 ...	-40 ... +240 °C (c)	-40 ... +240 °C	-40 ... +105 °C	-40 ... +105 °C
... 260 ...	-40 ... +260 °C (c) -40 ... +300 °C (s)	-40 ... +260 °C	-40 ... +105 °C	-40 ... +105 °C
... 370 ...	-40 ... +370 °C (c) -40 ... +400 °C (s)	-40 ... +400 °C	-40 ... +105 °C	-40 ... +105 °C
... 500 ...	-40 ... +500 °C (c) -40 ... +550 °C (s)	-40 ... +550 °C	-40 ... +105 °C	-40 ... +105 °C

(c) continuous; (s) short-time = max. 2 minutes

* When used in hazardous areas, the media and ambient temperature are limited according to the valid operating instructions

(9) Cable lengths of high temperature cable (HT-cable) in front of cable amplifier

design	description
for sensor design up to 240 °C, 260 °C, 370 °C and 500 °C*	
...-2/...	2 m fixed high temperature cable in front of cable amplifier * + 1.5 m low temperature cable (max. +105 °C) behind cable amplifier *

* special cable lengths for HT-cable in front of cable amplifier and standard cable after cable amplifier on request

Maximal lengths for high temperature cable (HT-cable) in front of cable amplifier

sensor type	max. temperature of sensor	max. length of HT-cable
ZSR	240 °C	4 m
ZS	260 °C	6 m
FT	260 °C	4 m
ZS	370 °C	6 m
ZS	500 °C	6 m

(10) Max. working pressure

... p3 ...	up to 3 bar / 0.3 MPa overpressure
... p6 ...	up to 6 bar / 0.6 MPa overpressure
... p10 ...	up to 10 bar / 1 MPa overpressure

Design / dimensions									
head	sensor-material A, E, T	drawing ZG ...	Ø K head [mm]	Ø S shaft [mm]	F vane wheel [mm]	LK length of head [mm]	B overhang [mm]	C length with HG [mm]	IG inside thread
ZS25	A	ZG1	25	25	18.2	60	13.4	170	M 22 x 1.5
ZS25	E, T	ZG1	25	25	18.2	81	13.9	169	M 22 x 1.5
ZS25/27	E	ZG2	25	27	18.2	75	13.9	315	M 22 x 1.5
FT25	A	ZG1	25	25	18.2	60	13.4	160	M 22 x 1.5
FT25	E, T	ZG1	25	25	18.2	81	13.9	169	M 22 x 1.5
ZSR25	A	ZG1	25	25	18.2	66	13.9	166	M 22 x 1.5
ZSR25	E, T	ZG1	25	25	18.2	66	13.9	154	M 22 x 1.5
ZS30	A, E, T	ZG1	30	30	24	90	18	170	M 26 x 1.5
ZSR30	A, E, T	ZG1	30	30	24	90	18	178	M 26 x 1.5
FT30	A	ZG1	30	30	24	90	18	178	M 26 x 1.5
FT30	E, T	ZG1	30	30	24	90	18	170	M 26 x 1.5

Option 'Ex-protexion'		
type of protection	article no.	remark
CE <Ex> II 3 G Ex ec IIC T6 Gc X gas-Ex: category 3G (zone 2)	FAEX2E *	in conjunction with evaluation unit
CE <Ex> II 3 D Ex tc IIIC TX Dc X dust-Ex: category 3D (zone 22)	FAEX2E *	in conjunction with evaluation unit
CE <Ex> II 2 G Ex ia IIC T6 Gb gas-Ex: category 2G (zone 1)	FAEX1 * FAEX1-3L * (for 500 °C sensor)	only in conjunction with: - isolation-/supply unit LDX2 <u>and</u> 'non-Ex evaluation unit' or - ATEX-conform, separate evaluation unit with v/FA-Ex or v/FAR-Ex input - not valid for FT-sensors

* remark: media and ambient temperature according to the valid operating instructions

Smallest measurable values, density influence

The smallest measurable value for measurements in air/gases specified in our documents results from a measuring medium density $\rho_{real} \cong 1.204 \text{ kg/m}^3$. The smallest measurable value v_0 is also increased/decreased negligibly even with a considerably different medium density from 1.204 kg/m^3 and follows in good approximation the relation:

$$v_{0,real} = v_{0,specif.} * \sqrt{1.204 \text{ kg/m}^3 / \rho_{real}}$$

The characteristic is displaced by the difference

$$v_{0,specif.} - v_{0,real} = \Delta v$$

Readout of measured values is too great by the amount Δv when measuring in gases of a density of ρ_{real} greater than 1.204 kg/m^3 , and too small by the amount Δv when measuring in gases of a density of ρ_{real} less than 1.204 kg/m^3 . Δv is to be added to or subtracted from the respective output value.

Evaluation unit connection

for unit with 8-pin screw-type connector

		article no.
plug 423-8	type of protection IP67	A099/056
plug 680-8	type of protection IP40	A099/055

for unit with connecting terminals

stripped cable end	marked strands with end sleeves	A099/110
--------------------	---------------------------------	----------

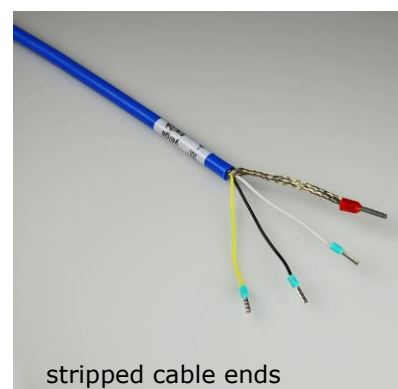

Extension rods

description	material	length	outside diameter	article no.
VS25A-350	aluminium, FKM-O-ring	350 mm	25 mm	B099/003
VS25A-1000	aluminium, FKM-O-ring	1000 mm	25 mm	B099/004
VS25E-350	stainless steel, FKM-O-ring	350 mm	25 mm	B099/005
VS25E-1000	stainless steel, FKM-O-ring	1000 mm	25 mm	B099/006
SR27E-400	stainless steel, graphite	400 mm	27 mm	B099/506
SR27E-1000	stainless steel, graphite	1000 mm	27 mm	B099/507
SR27E-1500	stainless steel, graphite	1500 mm	27 mm	B099/508
VS30A-350	aluminium, FKM-O-ring	350 mm	30 mm	B099/007
VS30A-1000	aluminium, FKM-O-ring	1000 mm	30 mm	B099/007-S01
VS30E-350	stainless steel, FKM-O-ring	350 mm	30 mm	B099/008
VS30E-1000	stainless steel, FKM-O-ring	1000 mm	30 mm	B099/009

direction indicator

	description	article no.
	direction indicator RZ25	B099/953
	direction indicator RZ27	B099/954
	direction indicator RZ30	B099/955

probe guide pieces *		
designation	description	articles no.
for diameter 25 mm		
SFB 25 E-70 / F-DN50 PN16 according drawing 1 (see page 11)	connection: flange DN50PN16 EN1092-1 max. pressure: 2 bar / 200 kPa temperature: -40 ... 550 °C materials: stainless steel, graphite fixation: clamping bush length L: 70 mm	B004/110
SFB 25 E-70 / F-ANSI 2" 150 lbs according drawing 1 (see page 11)	connection: flange 2" 150 lbs ANSI B16.5 max. pressure: 2 bar / 200 kPa temperature: -40 ... +240 °C materials: stainless steel, PTFE fixation: clamping bush length L: 70 mm	B004/110-S02
SFK 25 E-50 / G 1 1/4" according drawing 2 (see page 11)	connection: outside thread G 1 1/4" max. pressure: 10 bar / 1 MPa temperature: -20 ... +240 °C materials: stainless steel, FKM fixation: clamp yoke length L: 50 mm	B004/211
SFK 25 E-50 / NPT 1 1/4" according drawing 2 (see page 11)	connection: outside thread NPT 1 1/4" max. pressure: 10 bar / 1 MPa temperature: -20 ... +240 °C materials: stainless steel, FKM fixation: clamp yoke length L: 50 mm	B004/209
SFB 25 E-54 / G 1 1/4" according drawing 5 (see page 11)	connection: outside thread G 1 1/4" max. pressure: 2 bar / 200 kPa temperature: -20 ... +240 °C materials: stainless steel, FKM, PTFE fixation: clamping bush length L: 54 mm	B004/510
SFB 25 E-50 / NPT 1 1/4 " according drawing 5 (see page 11)	connection: outside thread NPT 1 1/4" max. pressure: 2 bar / 200 kPa temperature: -20 ... +240 °C materials: stainless steel, PTFE fixation: clamping bush length L: 50 mm	B004/523

* Probe guide pieces enable a process connection via threaded sleeve or flange connection. They are moveable and rotatable on the probe shaft. Other probe guide pieces on request.

probe guide pieces * (cont.)		
designation	description	articles no.
for diameter 27 mm		
SFB 27 E-70 / F-DN50 PN16 according drawing 1 (see page 11)	connection: flange DN50PN16 EN1092-1 max. pressure: 2 bar / 200 kPa temperature: -40 ... 550 °C materials: stainless steel, graphite fixation: clamping bush length L: 70 mm	B004/102- GRAPHIT
SFK 27 E-50 / G 1 1/4" according drawing 2 (see page 11)	connection: outside thread G 1 1/4" max. pressure: 10 bar / 1 MPa temperature: -20 ... +240 °C materials: stainless steel, FKM fixation: clamp yoke length L: 50 mm	B004/212
SFB 27 E-54 / G 1 1/4" according drawing 5 (see page 11)	connection: outside thread G 1 1/4" max. pressure: 2 bar / 200 kPa temperature: -40 ... 550 °C materials: stainless steel, graphite fixation: clamping bush length L: 54 mm	B004/502-S04
SFB 27 E-50 / NPT 1 1/2" according drawing 5 (see page 11)	connection: outside thread NPT 1 1/2" max. pressure: 2 bar / 200 kPa temperature: -40 ... 550 °C materials: stainless steel, graphite fixation: clamping bush length L: 50 mm	B004/502-S05
for diameter 30 mm		
SFB 30 E-45 / G 1 1/2" according drawing 5 (see page 11)	connection: outside thread G 1 1/2" max. pressure: 2 bar / 200 kPa temperature: -20 ... +240 °C materials: stainless steel, FKM, PTFE fixation: clamping bush length L: 45 mm	B004/508
* Probe guide pieces enable a process connection via threaded sleeve or flange connection. They are moveable and rotatable on the probe shaft. Other probe guide pieces on request.		

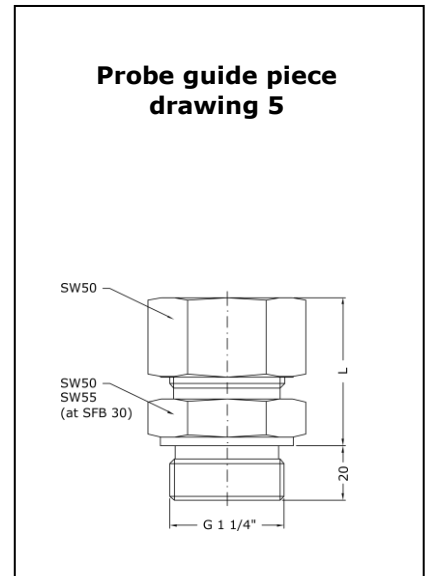
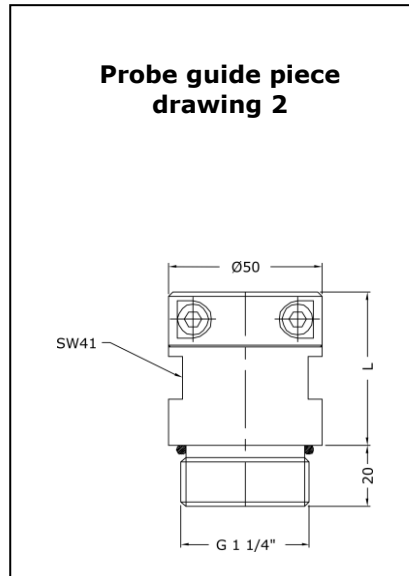
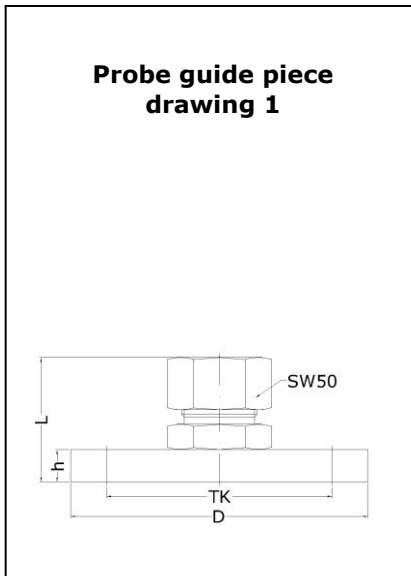

Profile factors depending on pipe inside diameter

measuring tube inside diameter Di [mm]	profile factor PF* [-]	measuring tube inside diameter Di [mm]	profile factor PF* [-]
50	0.735	120	0.882
60	0.760	170	0.938
70	0.784	180	0.945
80	0.807	220	0.955
90	0.829	230	0.960
100	0.849	...	0.960

* These profile factors are only accurate with centric sensor positioning, turbulent, non-rotational inlet flow and sufficiently dimensioned input and output sections (see Operating Instructions). The profile factor describes the ratio of average flow velocity in the measurement cross section area and the flow velocity measured from the sensor. The above mentioned operating conditions apply.

Sensor installation

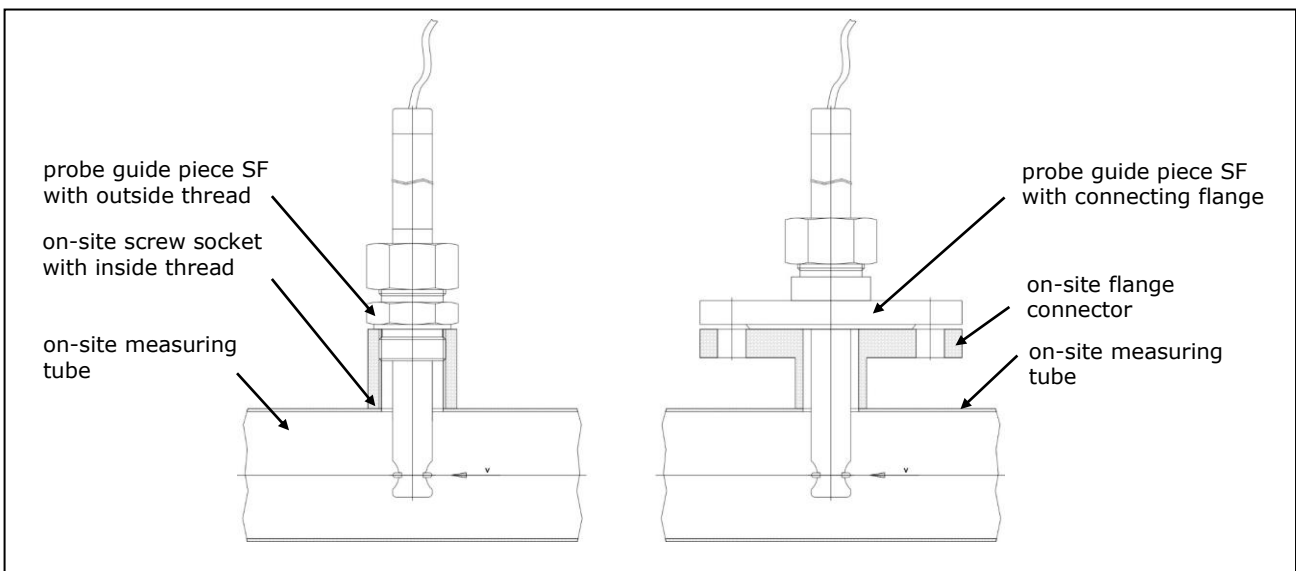

Wiring diagrams

ZS25_ZS30_100 °C_140 °C sensors

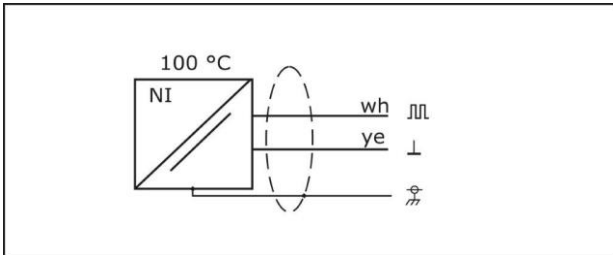

ZS25_ZS30_260 °C_350 °C_370 °C sensors

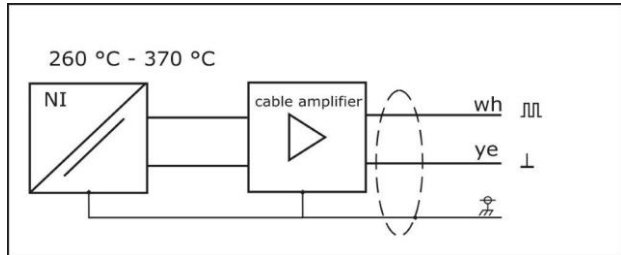

ZS25_500 °C sensors

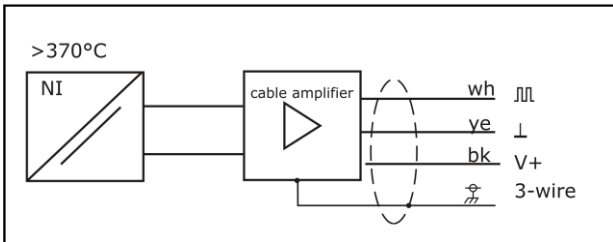

ZSR25_ZSR30_100 °C_140 °C sensors

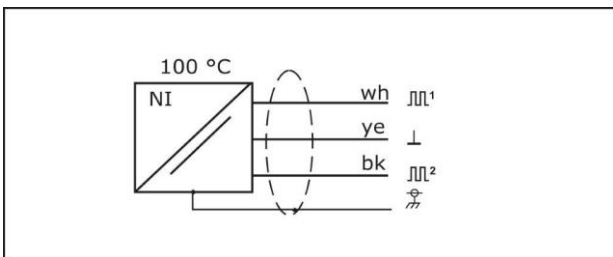

ZSR25_ZSR30_240 °C_ sensors

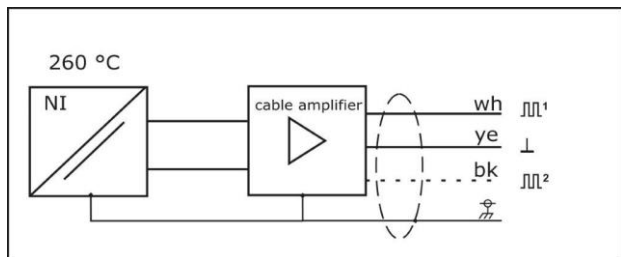

FT25_FT30_100 °C_140 °C sensors

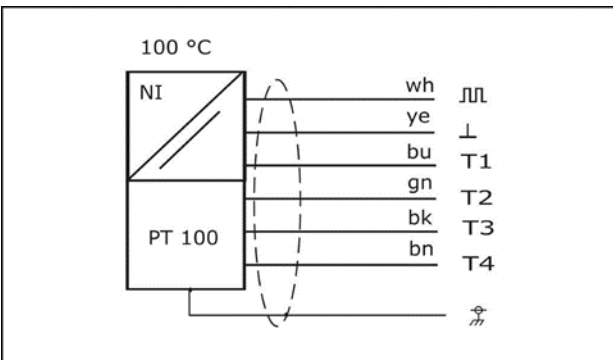

FT25_FT30_260 °C sensors

